

ENERGY SAVING
Digital Sampling Power Meters
with Superior Cost Performance
TOOLS

Digital Power Meters

WT 210/WT 230



- Basic accuracy: 0.1%
- DC measurement, 0.5 Hz to 100 kHz frequency range
- Compact design (half-rack size)
- 5 mA range for very low current measurements (model WT210 only)
- Line filter function
- High-speed data update (as fast as 10 readings per second)
- Harmonic measurement function available
- User calibration capability
- Large-current measurement capability using external sensor input

The WT210/WT230 has five times the high-frequency range and approximately twice the basic accuracy as the WT200/WT130.

The WT230's advanced specifications and its wide range of functions let you handle all your measurement applications from low-frequency equipment to high frequency inverters using a single power meter. One unit also handles standby low-power measurements and rated-power measurements (functions available with the WT210 only).

WT230



WT210

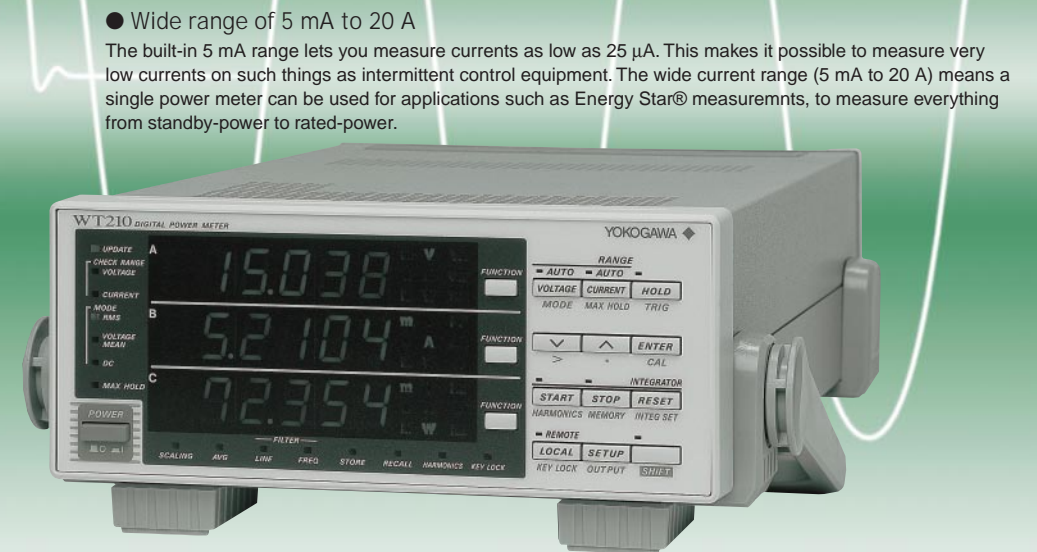

● Wide range of 5 mA to 20 A

The built-in 5 mA range lets you measure currents as low as 25 μ A. This makes it possible to measure very low currents on such things as intermittent control equipment. The wide current range (5 mA to 20 A) means a single power meter can be used for applications such as Energy Star® measurements, to measure everything from standby-power to rated-power.

Functions and Features of the WT210 and WT230

● A Wide Frequency Range Lets You Work on a Variety of Different Applications

NEW Low-frequency Equipment

Low-frequency measurements starting at 0.5 Hz can be used with evaluations of cycloconverter and when a motor are started.

NEW Commercial Power Supplies

Accuracy is even better than in former WT series.

NEW Inverters

Now you can obtain more precise measurements on high-frequency equipment such as inverters.

● Accuracy Is Assured between 1% and 130%

WT210: 50 μ A 1% * Conditions apply to accuracy from 110% to 130%. 130% 26A

● Capture a Variety of Signal Types

Surge current and maximum load state

MAX hold function for voltage, current, and power¹

This function lets you keep, on the display, voltage and current peak values, voltage and current rms values, and maximum values for active power, apparent power, and reactive power.

Half-wave Rectification, Intermittent Control, Distortion Waves

Measurement of DC components

In addition to using DC inputs, you can obtain precise measurements of signals containing DC components, such as intermittent signals and half-wave rectification signals.

Instead of taking notes, you can use the internal memory to store and recall settings and field measurement data.

NEW Constantly changing signals

Quick response with display updating as fast as every 0.1 second

With measurement intervals as short as 0.1 second, you can capture transient phenomena with a fine level of detail. You can also reduce the time per measurement for increased throughput in production testing.

NEW Noisy Signals

Line filter function ($f_c = 500$ Hz)

This function lets you measure fundamental wave rms values for inverter output voltages.

● Powerful Tools for Energy Measurement

Extended Energy Measurement Applications

Maximum integration time: 10,000 hours¹

Time can be set between 1 second and 10,000 hours (416 days) in 1-second increments.

Battery equipment applications

Integrating power measurement by polarity

Power and current values can be integrated separately for positive and negative polarities. Integrated values are shown with the decimal point moving according to the integrated value.

Intermittent Control Equipment Applications

Average active power display¹

The power of intermittent control equipment changes significantly over time. The average active power in intermittent operations can be displayed, which is highly effective for consumed-power measurements.

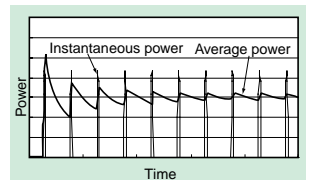

Average active power (W) = $\frac{\text{Integrated power (Wh)}}{\text{Integrated elapsed time (Hours)}}$

● Applications for a Variety of Add-on Options

Large-current Measurement Using Current Clamps

External input for current sensor

Select either 50/100/200 mV or 2.5/5/10 V. A current clamp lets you measure currents without needing to disconnect the power supply circuit wiring.

Online Power Meter Control and Recording

GP-IB/serial interface (RS-232-C)

This option lets you control the power meter through a PC, or save data to a PC.

Power Supply Harmonic Measurements

Calculate voltage, current, reactive power, content ratio, and phase angle relative to fundamental frequency for up to 50 orders. This option is well-suited to power supply environment evaluations. Measurement time is approximately 90% shorter than in former models.

Recording to a Recorder

D/A output

This option lets you output a variety of measurement data, such as voltage, current, and power measurements, with ± 5 V rating, for recording on a recorder. The recorder can then be used to check changes in data over time.

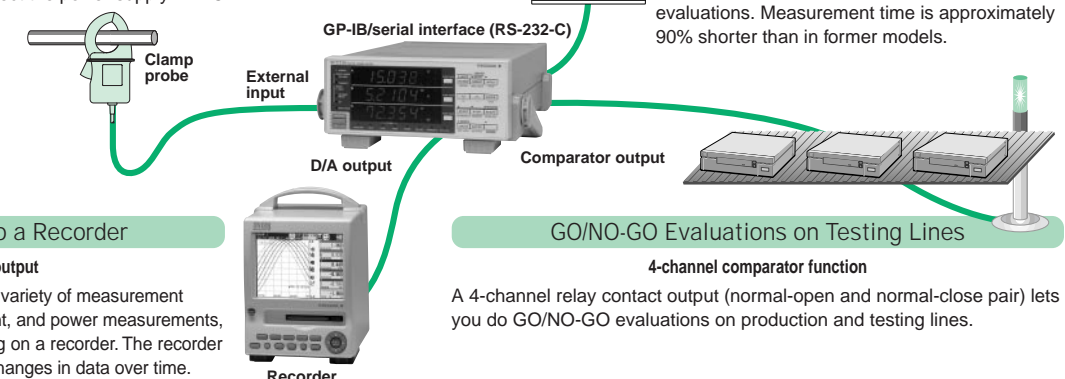

GO/NO-GO Evaluations on Testing Lines

4-channel comparator function

A 4-channel relay contact output (normal-open and normal-close pair) lets you do GO/NO-GO evaluations on production and testing lines.

Information on the features and functions of Yokogawa's WT210, WT230, accessories, and related products is also available at our web site. <http://www.yokogawa.com/tm/>

1: Popular functions on the WT200 were incorporated into WT210 and WT230.

Basic Characteristics

Example of Frequency-power Accuracy Characteristics

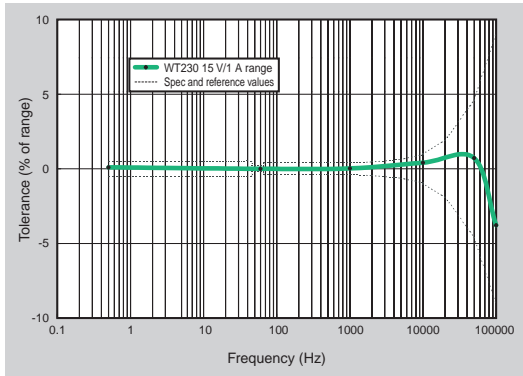

Example of WT210 Current Accuracy

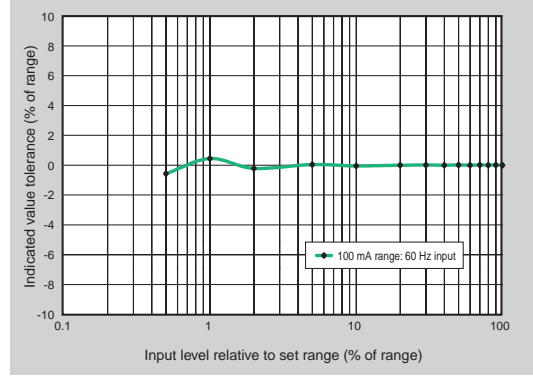

Current Input Surge Withstanding Ability

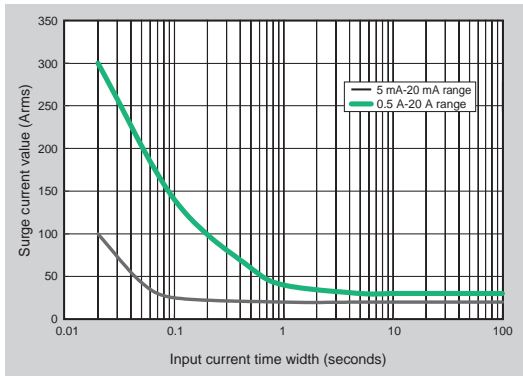

Example of Influence of Common Mode Voltage

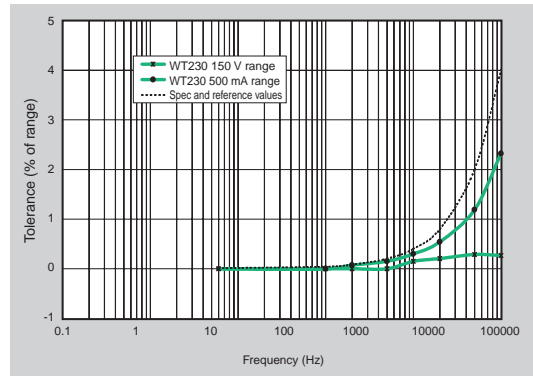

Example of D/A Output Response

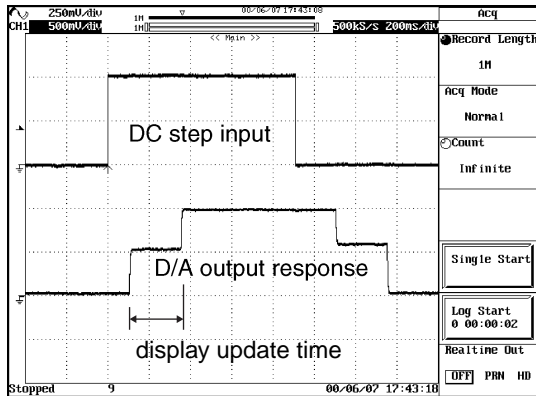

Comparison with Former Models

	WT200/WT130	WT210/WT230
Voltage input terminal	Binding post	Plug-in terminal (safety terminal)
External input terminal	Plug-in terminal (safety terminal)	BNC
Voltage and current basic accuracy	0.25% of rng	0.2% of rng
Power basic accuracy	0.3% of rng (WT200) 0.35% of rng (WT130)	0.2% of rng
Frequency range	DC, 10 Hz to 20 kHz	DC, 0.5 Hz to 100 kHz
Assured accuracy range	10% to 130% of range rating	1% to 130% of range rating
Display updating interval	0.25 second (fixed)	0.1/0.25/0.5/1/2/5 seconds
V, A, W display digits	4 digits (WT130) 5 digits (WT200)	5 digits
Line filter function	No	Yes (fc = 500 Hz)
Frequency filter function	Yes (fc = 300 Hz)	Yes (fc = 500 Hz)
Key lock	No	Yes
Harmonic measurement display updating interval	Approximately 3 seconds	0.25/0.5/1/2/5 seconds
Remote signals when comparator is installed	EXT HOLD and EXT TRIG are added. EXT START, EXT STOP, EXT RESET, and INTEG BUSY are not added.	All six signals listed to the left are added. Pin assign is changed.
Online data format	ASCII	ASCII, binary
Waveform data communications output	No	Yes
Addressable mode B for GP-IB communications	Yes	No
Display digits (factory default)	4 digits	5 digits
Online output data digits (factory default)	4 digits	5 digits

Functions Included with the WT200 (but Not Included with the WT130) and Included with the WT210/WT230

- MAX hold function
- Moving decimal point display based on integrated power value
- 10,000-hour maximum integration time
- Integration with few data omissions
- Average active power display



WT230



WT210

Specifications

The latest product information is available at our web site <http://www.yokogawa.com/tm/>. Review the specifications to determine which model is right for you.

Input Specifications		
Parameter	Voltage	Current
Input type	Floating input	
	Resistance voltage divider	Shunt input system
Rated values (ranges)	15/30/60/150/300/600 V	Direct input: 5/10/20/50/100/200 mA (WT210 only) ¹ ; 0.5/1/2/5/10/20 A (WT210/WT230) External input (optional): 2.5/5/10 V or 50/100/200 mV
Measuring instrument loss (input resistance)	Input resistance: Approximately 2 MΩ Input capacitance: Approximately 13 pF	Direct input: Approximately 500 mΩ + approximately 0.1 μH (5-200 mA; WT210) Approximately 6 mΩ + 10 mS (max) ² + approximately 0.1 μH (0.5-20 A; WT210) Approximately 6 mΩ approximately 0.1 μH (0.5-20 A; WT230) External input: Approximately 100 kΩ (2.5/5/10 V), approximately 20 kΩ (50/100/200 mA)
Maximum instantaneous allowed input (1 cycle, 20 ms duration)	Peak voltage of 2.8 kV or rms value of 2.0 kV (whichever is less)	0.5-20 A (WT210/WT230): Peak current of 450 A or rms value of 300 A (whichever is less) 5-200 mA (WT210): Peak current of 150 A or rms value of 100 A (whichever is less) External input: Peak value of 10 times range or less
Maximum instantaneous allowed input (1 second duration)	Peak voltage of 2.0 kV or rms value of 1.5 kV (whichever is less)	0.5-20 A (WT210/WT230): Peak current of 150 A or rms value of 40 A (whichever is less) 5-200 mA (WT210): Peak current of 30 A or rms value of 20 A (whichever is less) External input: Peak value of 10 times range or less
Maximum continuous allowed input	Peak voltage of 1.5 kV or rms value of 1.0 kV (whichever is less)	0.5-20 A (WT210/WT230): Peak current of 100 A or rms value of 30 A (whichever is less) 5-200 mA (WT210): Peak current of 30 A or rms value of 20 A (whichever is less) External input: Peak value of 5 times range or less
Maximum continuous common mode voltage (with 50/60 Hz input)	600 Vrms (with output connector protective cover), CAT II / 400 Vrms (without output connector protective cover) CAT II 50/60 Hz, -80 dB or higher (±0.01% of range or less) with voltage input terminals shorted and current input terminals open	
CMRR 600 Vrms across input terminal and case	Reference value (up to 100 kHz): ±((Maximum range rating)/(Range rating) × 0.001 × % of rng) or less (voltage range; 0.5-20 A current range) ±((Maximum range rating)/(Range rating) × 0.0002 × % of rng) or less (WT210; 5-200 mA range) Note: 0.01% or higher. f is in kHz.	
Input terminal type	Plug-in terminal (safety terminal)	Direct input: Large binding post External input: BNC
A/D converter	Simultaneous conversion of voltage and current inputs Resolution: 16 bits Maximum conversion speed: Approximately 20 μs (approximately 51 kHz)	
Range switching	Ranges can be set manually, automatically, or through online controls. Auto-range function Range raising: When a measurement exceeds 130% of the rating, or when the peak value exceeds approximately 300% of the rating Range lowering: When a measurement falls to 30% or less of the rating, and the peak value falls to approximately 300% or less of the rating for the low range	
Measurement mode switching	Any of the following, selected manually or through online controls: RMS (true rms value measurements for both voltage and current), V MEAN (calibration of average-value-rectified rms value for voltage; true rms value measurement for current), DC (simple averages for both voltage and current)	

Note: Current direct input and external sensor input cannot both be used at the same time. When switching inputs, note that there is a common terminal for both positive and negative polarities.

1, Connect wires that match the size of the measurement current.

2, Factory setting

Measurement Functions		
Parameter	Voltage/current	Active power
System	Digital sampling; sum of averages method	
Frequency range	DC, and 0.5 Hz to 100 kHz	
Crest factor	3 (with rated input)	
Display accuracy Accuracy (three months after calibration) (Conditions) Temperature: 23±5°C Humidity: 30-75% RH Supply voltage: 100 V ±5% Input waveform: Sinewave In-phase voltage: 0 V DC Frequency filter: ON at 200 Hz or less Scaling: OFF Display digits: 5 digits After CAL is executed As per Yokogawa standards	DC: ±(0.2% or rdg + 0.2% of rng)* 0.5 Hz ≤ f < 45 Hz: ±(0.1% of rdg + 0.2% of rng) 45 Hz ≤ f ≤ 66 Hz: ±(0.1% of rdg + 0.1% of rng) 66 Hz < f ≤ 1 kHz: ±(0.1% of rdg + 0.2% of rng) 1 kHz < f ≤ 10 kHz: ±((0.07 × f) of rdg + 0.3% of rng) 10 kHz < f ≤ 100 kHz: ±((0.5% of rdg + 0.5% of rng) ±((0.04 × (f-10))% of rdg)	DC: ±(0.3% or rdg + 0.2% of rng)* 0.5 Hz ≤ f < 45 Hz: ±(0.3% of rdg + 0.2% of rng) 45 Hz ≤ f ≤ 66 Hz: ±(0.1% of rdg + 0.1% of rng) 66 Hz < f ≤ 1 kHz: ±(0.1% of rdg + 0.2% of rng) 1 kHz < f ≤ 10 kHz: ±(0.04% of rdg + 0.3% of rng) 10 kHz < f ≤ 100 kHz: ±(0.5% of rdg + 0.5% of rng) ±((0.09 × (f-10))% of rdg)
Note: In the accuracy calculation formula, f is in kHz.	* Add +10 μA to the current DC accuracy.	* Add +10 μA × voltage reading to the power DC accuracy.
Power factor effect		For cosφ = 0 45 Hz ≤ f ≤ 66 Hz: Add ±0.2% of VA to display accuracy. Reference data (up to 100 kHz): ±((0.2 + 0.2 × f)% of VA) Indicated value tolerance for 0 < cosφ < 1 Add (tanφ × (effect when power factor = 0))% of power reading to the above power accuracy. Note: φ is the phase angle between voltage and current.
Effective input range	1-130% of voltage/current range rating (for accuracy at 110-130%, add the reading tolerance × 0.5 to the above accuracy)	
Accuracy (12 months after calibration)	Add the accuracy's reading tolerance (three months after calibration) × 0.5 to the accuracy three months after calibration.	
Line filter function	A low-pass filter can be inserted in the input circuit for measurement. The cutoff frequency (fc) is 500 Hz.	
Accuracy with line filter on	Voltage and current: Add 0.2% of rdg at 45-66 Hz. Add 0.5% of rdg below 45 Hz. Power: Add 0.3% of rdg at 45-66 Hz. Add 1% of rdg below 45 Hz.	
Temperature coefficient	±0.03% of range/°C at 5-18°C and 28-40°C.	
Display updating intervals	0.1/0.25/0.5/1/2/5 seconds	
Measurement lower limit frequency	Data updating rate	0.1 second 0.25 second 0.5 second 1 second 2 seconds 5 seconds
	Measurement lower limit frequency	25 Hz 10 Hz 5 Hz 2.5 Hz 1.5 Hz 0.5 Hz

rdg: Reading
rng: Range

Frequency Measurements

Measurement inputs: V1, V2, V3, A1, A2, or A3 (select one)

Measurement system: Reciprocal system

Measurement frequency ranges

100 ms: 25 Hz ≤ f ≤ 100 kHz

250 ms: 10 Hz ≤ f ≤ 100 kHz

500 ms: 5 Hz ≤ f ≤ 100 kHz

1 sec: 2.5 Hz ≤ f ≤ 100 kHz

2.5 sec: 1.5 Hz ≤ f ≤ 50 kHz

5 sec: 0.5 Hz ≤ f ≤ 20 kHz

Accuracy: ±(0.05% of rdg)

Conditions: Input equal to at least 30% of voltage/current rated range.
Frequency equal to at least 20% of frequency measurement range. Frequency filter function ON at 200 Hz and below.

Communication Functions

GP-IB or serial interface (RS-232-C) (select one)

GP-IB

Electrical and mechanical specifications:

Conform to IEEE Standard 488-1978 (JIS C1901-1987).

Functional specifications:

SH1, AH1, T5, L4, SR1, RL1, PR0, DC1, DT1, C0

Protocol: Conforms to IEEE Standard 488.2-1992.

Code used: ISO (ASCII) code

Addresses: 0-30 talker/listener addresses can be set.

Serial interface (RS-232-C)

Transmission mode: Asynchronous

Baud rates: 1200, 2400, 4800, 9600 bps

Specifications

Calculation Functions

		Single-phase 3-wire (2 voltages, 2 currents)	Three-phase 3-wire (2 voltages, 3 currents)	Three-phase 3-wire (3 voltages, 3 currents)	Three-phase 4-wire
Voltage ΣV		$(V1 + V3)/2$	$(V1 + V2 + V3)/3$	$(V1 + V2 + V3)/3$	
Current ΣA		$(A1 + A3)/2$	$(A1 + A2 + A3)/3$		
Active power ΣW		$W1 + W3$			$W1 + W2 + W3$
Reactive power var, Σvar	Normal measurement Vari = $\sqrt{(VA^2 - W^2)}$	$var1 + var3$			$var1 + var2 + var3$
Apparent power VA, ΣVA	Normal measurement $VAi = Vi \times Ai$	$VA1 + VA3$	$\frac{\sqrt{3}}{2}(VA1 + VA3)$	$\frac{\sqrt{3}}{2}(VA1 + VA2 + VA3)$	$VA1 + VA2 + VA3$
Power factor PF, ΣPF	Power factor PF, ΣPF $Pfi = Wi/ViVAi$	$\Sigma W/\Sigma VA$			
Phase angle deg, Σdeg	Phase angle deg, Σdeg $degi = \cos^{-1}(Wi/ViVAi)$	$degi = \cos^{-1}(\Sigma W/\Sigma VA)$			

Notes

- This equipment's apparent power (VA), reactive power (var), power factor (PF), and phase angle (deg) are calculated from voltage, current, and active power. (Therefore, if the input contains a distorted wave, the values may not match those of other measuring instruments based on different measurement principles.)
- If either voltage or current falls to 0.5% of the range rating or less, then the apparent power (VA) and reactive power (var) are displayed as zero, and errors are displayed for power factor (PF) and phase angle (deg).
- Leading and lagging phase detection accuracy is specified for voltage and current inputs equal to 50% of the rating or greater.
Detection accuracy: ± 5 deg (20 Hz to 2 kHz)
- In the Σvar calculation, the var value for each phase is calculated with a negative sign if the current input leads the voltage input, and with a positive sign if the current input lags the voltage input.

Display Functions

Display unit: 7-segment LED (light-emitting diode)
Display areas: 3

Display area	Displayed information
A	V, A, W, VA, var (for each element), integration elapsed time
B	V, A, W, PF, deg (for each element, percentage (content percentage, THD))
C	V, A, W, V/AHz, Vpk, Apk, $\pm Wh$, $\pm Ah$ (for each element), MATH

Measurement parameters	Maximum display	Display resolution
V, A, W, VA, var	99999	0.001%
PF	± 1.0000	0.01%
deg	± 180.0	0.1°
$\pm Wh$, $\pm Ah$	999999	0.0001%
VHz, AHz	99999	Input frequency/20,000

Display digits: 4 or 5 digits (selectable by user).
Factory default setting is 5 digits.

- Units: m, k, M, V, A, W, VA, var, Hz, \pm , deg, %
Display updating intervals: 0.1/0.25/0.5/1/2/5 seconds
Response time: Maximum 2 times the display updating interval (time required for display value to enter accuracy range of final value with line filter off, when range rating abruptly changes from 0% to 100%, and from 100% to 0%)

- Display scaling function
Effective digits: Selected automatically according to the digits in the voltage and current ranges.
Setting range: 0.001 to 9999
Averaging function
There are two averaging methods (selectable by user):
Exponential average
Moving average
In cases where response can be set and exponential average is used, the attenuation constant can be selected. In cases where a moving average is used, the number of averages N can be selected from 8, 16, 32, and 64.

- Auto-range monitor
An LED turns on when the input value is outside the range set for the auto-range.
MAX hold function
This function can be used to hold V, A, W, VA, var, Vpk, and Apk at maximum values.

- MATH functions
System: When a function key on DISPLAY C is pressed to select the MATH functions, it is possible to perform efficiency (WT230 only) and input crest factor measurements, as well as arithmetic calculations on DISPLAY A and B measurements. In addition, it is possible to display average active power for time-converted integrated power.

Integration Functions

- Display resolution: The minimum display resolution changes together with the integrated value.
Maximum display: -99999 to 999999 MWh/MAh
Modes: Standard integration mode (timer mode), continuous integration mode (repeat mode), manual integration mode
Timer: Automatic integration start/stop based on timer setting.
Setting range: 000 h:00 min:00 sec to 10000 h:00 min:00 sec (If the time is set to zero, manual mode is automatically set.)
Count over flow: When the integrated value exceeds 999999 MWh/MAh or falls to at least -99999 MWh/MAh, the elapsed time is saved and the operation is stopped.
Accuracy: \pm (display accuracy + 0.1% of rdg)
Timer accuracy: $\pm 0.02\%$
Remote control: Starting, stopping, and resetting can be controlled through external contact signals. This function is only available when option /DA4 or /DA12 is installed.

Internal Memory Functions

Measurement data	Stored data	Normal measurement	Harmonic measurement
WT210 (760401)	Data for 600 samples	Data for 30 samples	Data for 30 samples
WT230 (760502)	Data for 300 samples	Data for 30 samples	Data for 30 samples
WT230 (760503)	Data for 200 samples	Data for 30 samples	Data for 30 samples

- Store interval: Display updating interval and 1 second to 99 hours, 59 minutes, and 59 seconds
Recall interval: Display updating interval and 1 second to 99 hours, 59 minutes, and 59 seconds (Both can be set in 1-second increments.)
Panel setting information: Four different patterns of panel setting information can be written/read.

Harmonic Measurement Function (optional)

- System: PLL synchronization
Measurement frequency range: Fundamental frequency in range of 40-440 Hz
9999 or 20000
Display resolution: 9999 or 20000
Analysis parameters: V, A, W, deg (WT210), V1, V2, V3, A1, A2, A3, W1, W2, W3, deg1, deg2, deg3 (WT230), individual harmonic levels, rms voltage, rms current, active power, fundamental frequency PF, harmonic distortion rate, individual harmonic content
Note: These parameters can only be analyzed simultaneously for a single specified input module.

- Sampling speed, window width, and analysis orders
The values for these parameters vary according to the input fundamental frequency as shown below.
- | Fundamental frequency | Sampling speed | Window width | Analysis orders |
|--------------------------|-------------------|-----------------|-----------------|
| $40 \leq f < 70$ Hz | $f \times 512$ Hz | 2 periods of f | 50 |
| $70 \leq f < 130$ Hz | $f \times 256$ Hz | 4 periods of f | 50 |
| $130 \leq f < 250$ Hz | $f \times 128$ Hz | 8 periods of f | 50 |
| $250 \leq f \leq 440$ Hz | $f \times 64$ Hz | 16 periods of f | 30 |

- FFT data length: 1024
FFT processed word length: 32 bits
Window function: Rectangular
Display updating interval: 0.25/0.5/1/2/5 seconds Updating is slower during online output according to the communication speed and the number of parameters transferred.
Accuracy: Add $\pm 0.2\%$ of range to normal measurement accuracy.
Note: For nth-order component input, add ((nth order reading) $\times (10/(m+1))\%$) to the n+1th order and n-mth order.

D/A Output (optional)

- Output voltage: ± 5 V FS (maximum approximately ± 7.5 V) for each rated value
Number of outputs: 12 parameters with /DA12 option; 4 parameters with /DA4 option
Output data selection: Can be set separately for each channel.
Accuracy: \pm (equipment accuracy + 0.2% of FS)
Updating interval: Same as the equipment's display updating interval
Temperature coefficient: $\pm 0.05\%$ °C of FS
Output type

Frequency

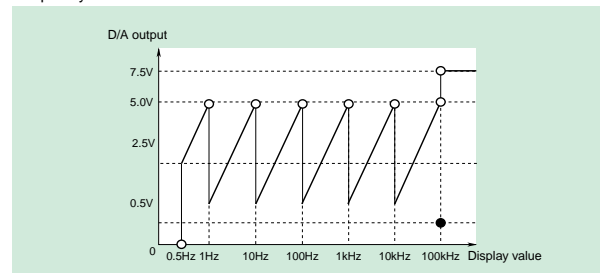

Integration

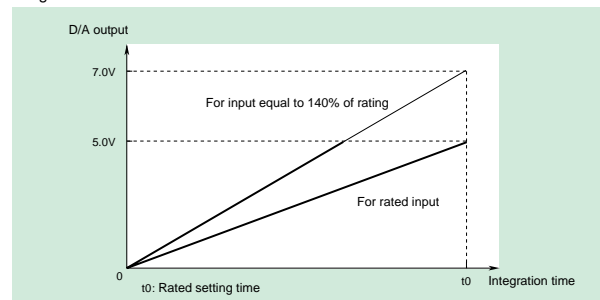

Other parameters

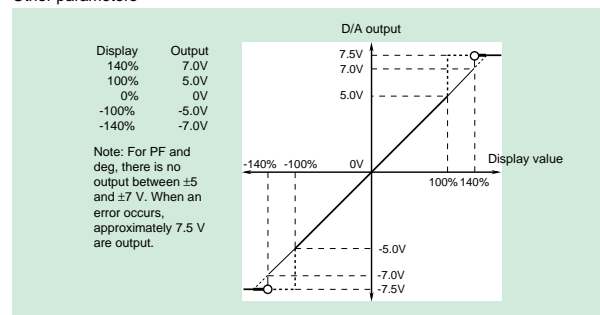

External Input (Optional)

Select either /EX1 or /EX2 for the voltage output-type current sensor.
 /EX1: 2.5/5/10 V
 /EX2: 50/100/200 mV
 Specifications: See the section on input specifications.

Comparator Output (Optional)

Output method: Normal-open and normal-close relay contact output (pair)
 Number of output parameters and settings: Four parameters; can be set separately on each output channel.
 Contact capacitance: 24 V/0.5 A
 D/A output (4-channel): See section on D/A output (optional)

External Control Signal (with D/A or /CMP Option Only)

External control signals: EXT-HOLD, EXT-TRIG, EXT-START, EXT-STOP, EXT-RESET, INTEG-BUSY
 Input: TTL level negative pulse

General Specifications

Warmup time: Approximately 30 minutes
 Operating temperature and humidity ranges: 5-40°C, 20-80% RH (no condensation)
 Storage temperature: 25-60°C (no condensation)
 Maximum operating elevation: 2000 meters
 Insulating resistance: 50 MΩ or higher at 500 V DC across all of the following areas:
 Voltage input terminals (ganged) and case
 Current input terminals (ganged) and output terminals (ganged)
 Voltage input terminals (ganged) and current input terminals (ganged)
 Voltage input terminals (ganged) of each element
 Current input terminals (ganged) of each element
 Voltage input terminals (ganged) and power plug
 Current input terminals (ganged) and power plug
 Case and power plug

Insulating withstand voltage:
 3700 V for one minute at 50/60 Hz across all of the following areas:
 Voltage input terminals (ganged) and case
 Current input terminals (ganged) and output terminals (ganged)
 Voltage input terminals (ganged) and current input terminals (ganged)
 Voltage input terminals (ganged) of each element
 Current input terminals (ganged) of each element
 Voltage input terminals (ganged) and power plug
 Current input terminals (ganged) and power plug
 1500 V for one minute at 50/60 Hz across case and power plug

Power supply: Free power supply (100-240 V), 50/60 Hz frequency
 Consumed power: Max 35 VA for WT210, max 55 VA for WT230
 External dimensions for WT210: Approximately 213 × 88 × 350 mm (WHD) (excluding projections)
 External dimensions for WT230: Approximately 213 × 132 × 350 mm (WHD) (excluding projections)
 Weight: Approximately 3 kg for WT210, approximately 5 kg for WT230

Exterior View

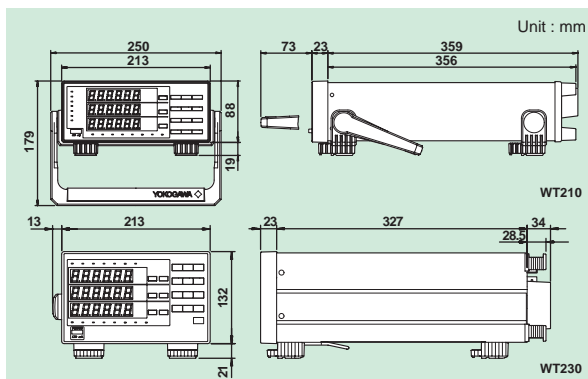

Wiring Types and Model Numbers

Wiring	Model	760401	760502	760503
Single-phase 2-wire		✓	✓	✓
Single-phase 3-wire		-	✓	✓
Three-phase 3-wire (2 voltages, 2 currents)		-	✓	✓
Three-phase 3-wire (3 voltages, 3 currents)		-	-	✓
Three-phase 4-wire		-	-	✓

Due to the nature of this product, it is possible to touch its metal parts. Therefore, there is a risk of electric shock, so the product must be used with caution.

Model Numbers and Suffix Codes

Model number	Suffix code	Description	
760401		WT210 single-input element model	
Power cord	-D	UL/CSA standard	
	-F	VDE standard	
	-R	SAA standard	
	-Q	BS standard	
Options	/C1	GP-IB communication interface	Select one
	/C2	Serial (RS-232-C) communication interface	
	/EX1	External input 2.5/5/10 V	Select one
	/EX2	External input 50/100/200 mV	
	/HRM	Harmonic analysis function	
	/DA4	4-channel DA output	Select one
	/CMP	Comparator and D/A, 4 channels each	

Note: The WT210 communication interface cannot be changed or modified after delivery.

Model number	Suffix code	Description	
760502		WT230 2-input element model	
760503		WT230 3-input element model	
Interface	-C1	GP-IB communication interface	Select one
	-C2	Serial (RS-232-C) communication interface	
Power cord	-D	UL/CSA standard	
	-F	VDE standard	
	-R	SAA standard	
	-Q	BS standard	
Options	/EX1	External input 2.5/5/10 V	
	/EX2	External input 50/100/200 mV	Select one
	/HRM	Harmonic analysis function	
	/DA12	12-channel DA output	
	/CMP	Comparator and D/A, 4 channels each	Select one

Rack mounts

Product	Model or part number	Specification	Order quantity
Rack mounting kit	751533-E2	For WT210 EIA standalone installation	1
Rack mounting kit	751533-J2	For WT210 JIS standalone installation	1
Rack mounting kit	751534-E2	For WT210 EIA connected installation	1
Rack mounting kit	751534-J2	For WT210 JIS connected installation	1
Rack mounting kit	751533-E3	For WT230 EIA standalone installation	1
Rack mounting kit	751533-J3	For WT230 JIS standalone installation	1
Rack mounting kit	751534-E3	For WT230 EIA connected installation	1
Rack mounting kit	751534-J3	For WT230 JIS connected installation	1

Ask Yokogawa for information on rack mounts in which WT210 and WT230 are combined.

Accessories (sold separately)

Model number	Description
B9317WD	1.5 mm Allen wrench For fastening cable on 758931
B9284LK	External sensor cable For external input; 50 cm

758917

Measurement leads

Two leads (one red and one black) in a set. Alligator adapters are sold separately. Use 758917 in combination with 758922 or 758929.
 Total length: 75 cm
 Rating: 1000 V



758929

Large alligator adapters

For connection to measurement leads (758917). Two in a set.
 Rating: 1000 V



758922

Small alligator adapters

For connection to measurement leads (758917). Two in a set.
 Rating: 300 V



758931

Safety terminal adapter set

Screw-fastened adapters. Two adapters (one red and one black) in a set. 1.5 mm Allen wrench included for tightening.

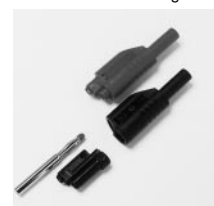

Related Products

- For current measurements with wires connected

751550 Clamp Probe

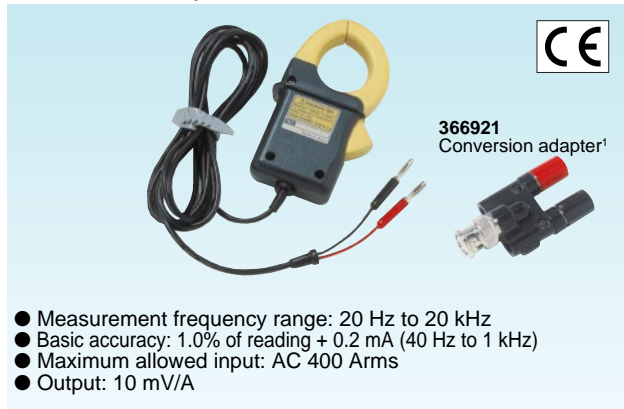

- Measurement frequency range: 20 Hz to 20 kHz
- Basic accuracy: 1.0% of reading + 0.2 mA (40 Hz to 1 kHz)
- Maximum allowed input: AC 400 Arms
- Output: 10 mV/A

A separately sold adapter (366921) is required for connection to WT210/WT230. For detailed information, see Power Meter Accessory Catalog Bulletin 7515-52E. This model is treated as a special-order product.
1 Use with low-voltage circuits (42 V or less).

- For high precision (0.05% + 40 μ A)

751574 Current Transducer

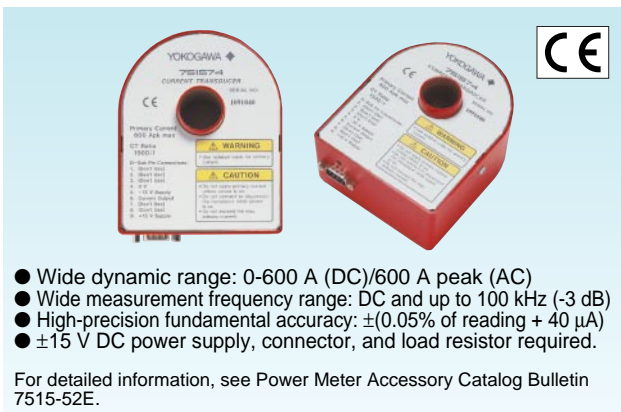

- Wide dynamic range: 0-600 A (DC)/600 A peak (AC)
- Wide measurement frequency range: DC and up to 100 kHz (-3 dB)
- High-precision fundamental accuracy: $\pm(0.05\%$ of reading + 40 μ A)
- ± 15 V DC power supply, connector, and load resistor required.

For detailed information, see Power Meter Accessory Catalog Bulletin 7515-52E.

- For simultaneous measurement of two separate three-phase systems using up to six elements

WT1600 Digital Power Meter

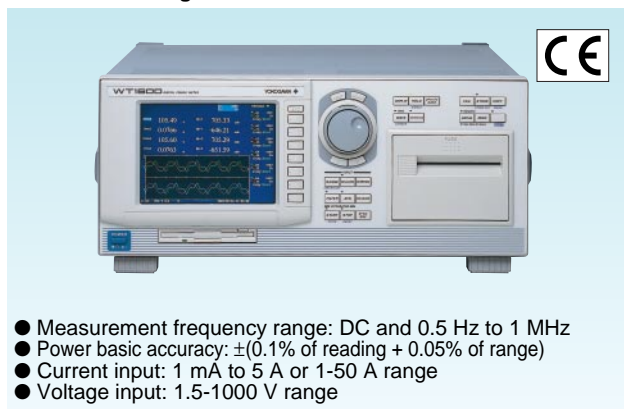

- Measurement frequency range: DC and 0.5 Hz to 1 MHz
- Power basic accuracy: $\pm(0.1\%$ of reading + 0.05% of range)
- Current input: 1 mA to 5 A or 1-50 A range
- Voltage input: 1.5-1000 V range

Protecting the global environment

Yokogawa's products are developed and produced in facilities that have received ISO14001 approval.

- For high-current measurements up to 1000 Arms

751552 Clamp Probe

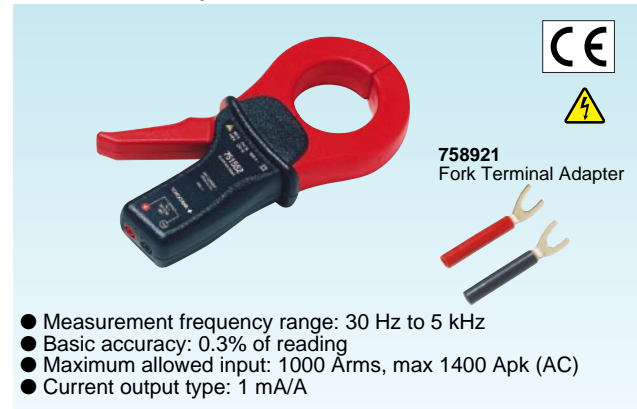

- Measurement frequency range: 30 Hz to 5 kHz
- Basic accuracy: 0.3% of reading
- Maximum allowed input: 1000 Arms, max 1400 Apk (AC)
- Current output type: 1 mA/A

A separately sold fork terminal adapter set (758921), measurement leads (758917; see photo above), etc. are required for connection to WT210/WT230. For detailed information, see Power Meter Accessory Catalog Bulletin 7515-52E.

- For harmonic and flicker measurements

WT2010/WT2030 Digital Power Meters

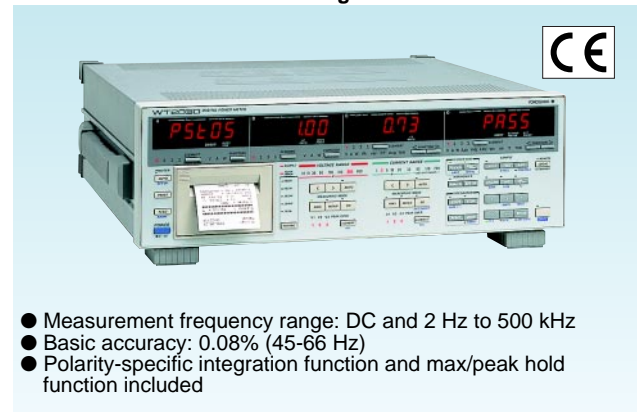

- Measurement frequency range: DC and 2 Hz to 500 kHz
- Basic accuracy: 0.08% (45-66 Hz)
- Polarity-specific integration function and max/peak hold function included

- Innovative power meter for capturing power changes as waveforms

PZ4000 Power Analyzer

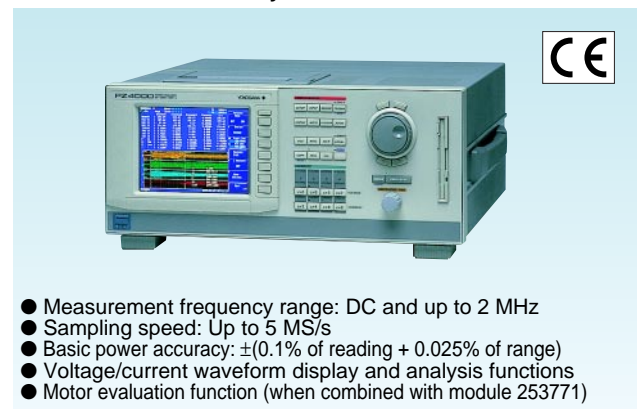

- Measurement frequency range: DC and up to 2 MHz
- Sampling speed: Up to 5 MS/s
- Basic power accuracy: $\pm(0.1\%$ of reading + 0.025% of range)
- Voltage/current waveform display and analysis functions
- Motor evaluation function (when combined with module 253771)

CAUTION



- Read the user's manual carefully for correct and safe use of the instrument.

YOKOGAWA

YOKOGAWA ELECTRIC CORPORATION

Test and Measurement Business Div./Phone: (81)-55-243-0313, Fax: (81)-55-243-0396

E-mail: tm@csv.yokogawa.co.jp

YOKOGAWA CORPORATION OF AMERICA

Phone: (1)-770-253-7000, Fax: (1)-770-251-2088

YOKOGAWA EUROPE B.V.

Phone: (31)-33-4641806, Fax: (31)-33-4641807

YOKOGAWA ENGINEERING ASIA PTE. LTD

Phone: (65)-62419933, Fax: (65)-62412606

Subject to change without notice.

[Ed : 01/b] Copyright ©2002

Printed in Japan, 205(YG)

MS-12E